



AC Servo Drives

For Rotary and Linear AC Servo Motors



The Most-Used Automation Language

Servo Drive Solutions

Baldor offers a wide choice of cost effective and easy to use servo drives. Whether your needs call for control of speed or torque, preset point-to-point moves, or a fully programmable single axis positioner/drive, then Baldor has the answer. A range of servo motors, linear motors and multi-axis motion controllers complement the range and provides you with a complete automation solution.

Getting Started Quickly

Baldor's servo drives have been designed for ease of use the moment you take them out of the box. Start the accompanying Windows-based program, Mint WorkBench and the wizard will take you through, step by step, all of the commissioning steps necessary to get the motor moving. Simply select your Baldor rotary or linear catalog model number from the database and answer some simple application questions.

Full auto-tune of current, velocity and position loops will get you up and running quickly, delivering optimum performance. Auto-tuning will even test that the motor cables have been correctly wired and the feedback is in the correct orientation.

Flexibility and Versatility

Baldor's servo drives offer the best in flexibility and versatility - whether the application needs a simple servo drive or a more sophisticated indexer or programmable drive.

The MicroFlex and FlexDrive-II drives provide torque or velocity control for interfacing direct to an external motion controller or PLC.

Programmability

If your application calls for point-to-point moves then the Flex+Drive-II will handle this. Preset position or speeds can be programmed from an easy to use table configuration tool. Flex+Drive-II is more than just a simple indexer, it is also fully programmable in Baldor's motion programming language Mint. This allows you to deal with more complex situations without having to rely on external logic such as a PLC.

If the application demands more sophisticated move types such as electronic cams, or flying shears, then Baldor's award winning MintDrive-II will handle this with ease. MintDrive-II incorporates the power and flexibility of a motion controller and drive in one box. Programmable in multitasking Mint, MintDrive-II shares many of the features of Baldor's NextMove range of multi-axis motion controllers.

With its optional CANopen interface, peer-to-peer networking is supported on MintDrive-II. The MintDrive-II can communicate with Baldor's range of NextMove motion controllers and Flex+Drive-II to provide a complete distributed control system.



P12
MicroFlex® e100
ETHERNET Powerlink or
CANopen DS402 operation



P14
MicroFlex®
Economical solution



P16
H2™ Servo
Simple keypad setup



P18

EuroFlex™

Rack mount Eurocard format servo drive

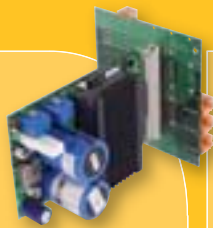

P20

FlexDrive-II

Fully featured servo drive



P20

Flex+Drive®-II

Point-to-point moves or Mint programmable



P24

MintDrive®-II

Fully featured integrated motion controller with multitasking capabilities



› Total Automation Solutions



HMI

- Text Displays
- Touch Panels
- Graphics panels
- PC Software



Motion

- PCI Cards
- Panel Mount
- Ethernet
- 3u Rack mount



Drives

- Servo
- Programmable Vector
- Inverter



Motors

- Rotary / Linear
- Servo
- Induction
- Stepper



Accessories

- Cables
- Power supplies
- Filters
- Gearboxes

Baldor is one of the industry leaders in providing a complete solution for multi-axis automation applications. The full range of multi-axis motion controllers, high performance servo drives, rotary servo motors and linear motors are designed to seamlessly interface with each other. This allows you to get on with the important task of bringing your machine to market.



Simple Set-up

Set-up and diagnostics is performed by Mint WorkBench - the same tool as used with Baldor's NextMove range of motion controllers. Set-up is performed from a simple wizard driven front end where standard Baldor motors are selected from a drop-down. For custom motors, Mint WorkBench can calculate key parameters such as motor inductance, resistance and inertia. Only the simplest of data needs to be entered keeping set-up time to a minimum. The auto-tune process will even detect incorrect wiring of the motor and feedback and electronically correct them.

Industry Standard Interface

Baldor's servo drives accept the industry standard $\pm 10V$ interface, programmable for torque or velocity demand. An encoder output interface provides connection to external motion controllers such as Baldor's own NextMove range or a PLC.

Choice of Feedback Options

A number of feedback options are available to suit the application. Both resolver and encoder feedback are supported on MicroFlex, H2 and Series-II drives. Absolute encoder interfaces are supported on MicroFlex e100 and Series-II. All feedback options are available on Baldor's extensive range of rotary servo motors.

Flexible Machine Controllers

Baldor's Series-II servo drives offers flexible machine controller solutions. Onboard I/O can interface to external devices such as PLCs and HMI devices. I/O is programmable through Mint WorkBench. Both the Flex+Drive-II and MintDrive-II servo drives are fully programmable in Baldor's highly acclaimed Mint programming language. MintDrive-II makes the ideal machine controller for single axis applications. The optional CANopen interface provides peer-to-peer networking for multi-axis type applications.

High Speed Registration Inputs

MicroFlex e100, Flex+Drive-II and MintDrive-II are equipped with high speed position latch inputs. These can latch position to within 1 micro-second. This real-time data can be used to make decisions about product position and is ideally suited to applications such as labeling, packaging machines and printing lines.

Choice of Communication Interfaces

Baldor's servo drive range are equipped with a range of communication interfaces including standard RS232/485 programming ports. The MicroFlex e100 and H2 servo drives have an onboard USB port for fast connection to PCs.

Series-II and H2 drives have the option of fieldbus interfaces including CANopen, DeviceNet and Profibus-DP. A web server option, with Ethernet interface is available for the H2.

Our latest generation MicroFlex e100 comes equipped with a real-time Ethernet interface supporting ETHERNET Powerlink. This replaces the traditional $\pm 10V$ and encoder signals with a single Ethernet cable.

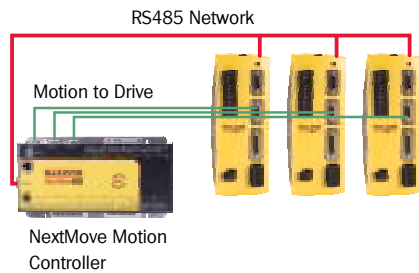

▲ RS485 communications provide a cost effective diagnostics network for up to 32 devices. Drives can be connected to a NextMove controller providing status information such as error, I/O status and position.

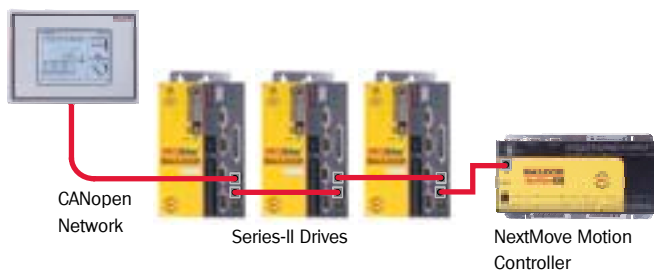

▲ Baldor's CANopen implementation provides peer-to-peer networking between the NextMove range of motion controllers, Flex+Drive-II and MintDrive-II. Data can be passed between nodes to each node's Mint program.

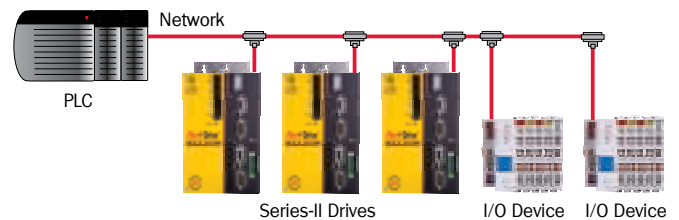

▲ DeviceNet, Profibus-DP and CANopen are supported on the Series-II range of drives. Access to an executing Mint program is provided by means of the Mint Comms Array. Commands, such as moves and gain scheduling can be performed over the network.

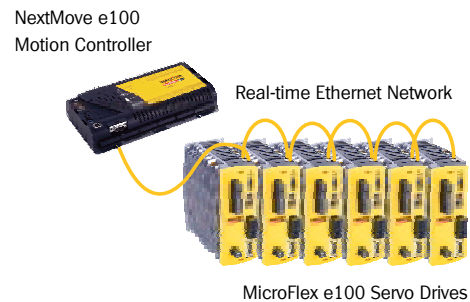

▲ MicroFlex e100 is our latest generation servo drive. MicroFlex e100 sports a real-time Ethernet link, utilizing ETHERNET Powerlink. Using our new NextMove e100 multi-axis motion controller, up to 16 axes of interpolated motion and over 200 axes of indexing motion can be achieved. Alternatively, MicroFlex e100 can be configured for standard TCP/IP mode for interfacing with the factory network for remote diagnostics, set-up or simple indexing motion.



Refer to catalog BR1202-I for full information on Baldor's real-time Ethernet Solution



Product Overview

	MicroFlex e100	MicroFlex	H2 Servo	EuroFlex	FlexDrive-II	Flex+Drive-II	MintDrive-II
Single Phase (VAC)	105-230	105-230	115 or 230	18-56	115 or 230	115 or 230	115 or 230
Current Ratings (Single Phase) Cont.	3, 6, 9	3, 6, 9	3-54	5	2.5, 5, 7.5	2.5, 5, 7.5	2.5, 5, 7.5
Three Phase (VAC)	230	230	230 or 460	-	230-460	230-460	230-460
Current Ratings (Three Phase) Cont.	3, 6, 9	3, 6, 9	3 - 54 ⑥	-	2.5, 5, 7.5, 15, 20, 27.5	2.5, 5, 7.5, 15, 20, 27.5	2.5, 5, 7.5, 15, 20, 27.5
Peak Overload (secs)	200% (3s)	200% (3s)	200% (3s) 150% (60s)	300% (3s)	200% (1.25-2.8s)	200% (1.25-2.8s)	200% (1.25-2.8s)
Control Logic Supply	24VDC	24VDC	Onboard	24VDC	24VDC ①	24VDC ①	24VDC ①
Digital Inputs	3 + DE	1 + DE	8 + DE	1 + DE	8 + DE	8 + DE ②	8 + DE ②
Digital Outputs	2	1	2 + Exp	1	3	3 ②	3 ②
Relay Output	0	0	2 + Exp	0	1	1	1
Analog Inputs	0	1x 14-bit	2x 12-bit	1x 14-bit	1x 14-bit	1x 14-bit	2x 14-bit
Analog Outputs	0	0	2 + Exp	0	0	0	2x 8-bit
Encoder Output	0	1	1	1	1	1	1
Master Encoder (Handwheel) Input	0	0	Option	0	1	1	1
Step and Direction Inputs	0	24V	0	24V or 5V	24V or 5V	24V or 5V	24V or 5V
Keypad Configuration	□	□	■	□	□	□	□
Mint WorkBench Configuration	■	■	■	■	■	■	■
Auto-tune	■	■	■	■	■	■	■
Space Vector Modulation Control	■	■	■	■	□	□	□
Digital Filters	■	■	■	■	□	□	□
Mint Programmable	□	□	○ ④	□	□	■ ⑤	■
Motor Feedback Options							
Resolver Feedback	□	○	○	□	○	○	○
Commutating Encoder Feedback	■	■	○	■	○	○	○
Hall-effect Feedback	■	■	○	■	○	○	○
EnDat Feedback	■	□	□	□	○	○	○
SSI Feedback	■	■	□	□	□	□	□
Communications							
RS232 Serial Port	□	■	□	■	■ ③	■ ③	■ ③
RS485 Serial Port	□	■	■	■	■ ③	■ ③	■ ③
USB Commissioning Port	■	□	■	□	□	□	□
ETHERNET Powerlink	■	□	○ ④	□	□	□	□
Ethernet TCP/IP	■	□	○	□	□	□	□
CANopen DS402 Slave	■	□	□	□	□	□	□
CANopen (DS301) Master	■	□	□	□	□	□	○
DevicetNet Slave	□	□	○	□	○	○	○
Profibus-DP Slave	□	□	○	□	○	○	○
Modbus-RTU	□	□	■	□	□	□	□

① Optional on single phase drives

② Upgradable for 10 additional inputs and 5 additional outputs

③ User selectable from DIP switch

④ Available 2006

⑤ Single task only, with indexing and gearing move types only

⑥ De-rate to 27A for 340-528VAC input

DE - Drive Enable

Exp - Expansion Card (Option)

■ Supported

□ Not Supported

○ Option

Single Axis and Multi-Axis Solutions

Baldor's servo drives are ideally suited for both single and multi-axis automation applications. Interfacing to Baldor's multi-axis controllers. Intelligent drives (Flex+Drive-II, MintDrive-II) can operate as independent machine controllers.

For operator interfaces, the Baldor HMI panels are supported through RS232 or CANopen interfaces. Alternatively, the supplied ActiveX controls can be used to provide a PC front end.

Multi-axis applications are easily addressed with Baldor's range of NextMove multi-axis motion controllers. Available from 1 through to 16 axes of interpolated control, the most demanding of applications can be accomplished. Alternatively, MintDrive-II and Flex+Drive-II drives can be networked together over the optional CANopen interface to provide a distributed control system for loosely coupled multi-axis applications.

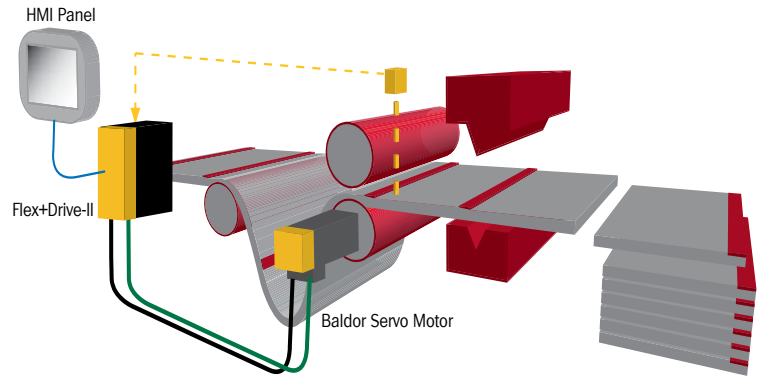

▲ Single axis indexer using MintDrive-II as machine controller with Baldor HMI operator interface.

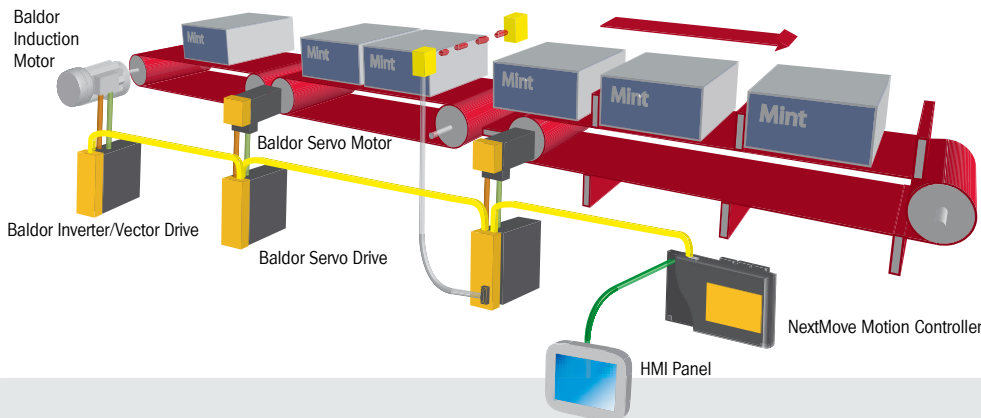

◀ Multi-axis product correction application, using NextMove motion controller as machine controller and Baldor servo drives

Space Vector Modulation Improves Efficiency

By controlling the IGBT power devices using Space Vector Modulation (SVM) instead of the more usual carrier based pulse width modulation (PWM), users can run servo motors at higher speeds without introducing harmonics. In today's world of increased productivity, this can translate directly into greater machine throughput. SVM is supported by MicroFlex, MicroFlex e100, EuroFlex and H2.

Digital Filters Eliminate Resonance

Advanced digital filtering techniques can be applied to reduce the effect of mechanical resonance on system performance.

The drive has two separate digital filters. Each can be adapted to specific frequencies as notch filters, or as low pass filters. Adapting the filters to eliminate or reduce the effects of resonance allow higher system gains and tighter control to be attained. This maximizes machine control bandwidth, without suffering from the increased resonance and performance degradation that would otherwise result.

Configuring these filters is aided by a simple filter design interface which, combined with the Mint WorkBench oscilloscope and FFT (Fast Fourier Transform) analysis, allows the user to test the axis open and closed loop frequency response. The resonant components can then be identified and filter designs tested for effectiveness.

Digital filters are supported by MicroFlex, MicroFlex e100, EuroFlex and H2.

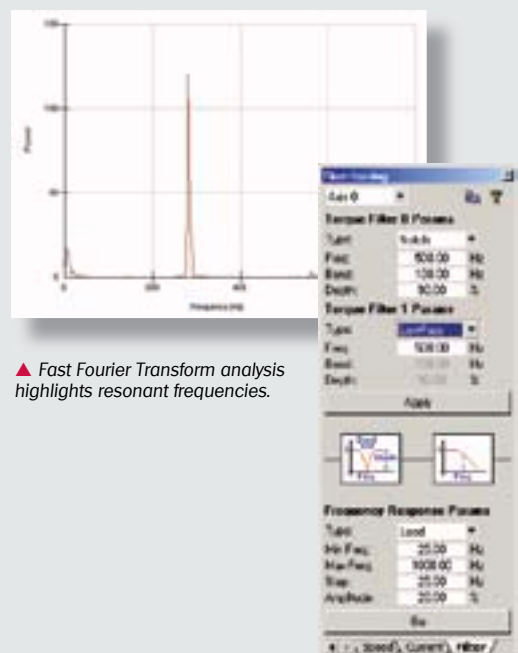

▲ Fast Fourier Transform analysis highlights resonant frequencies.

Mint[®] – The Programming Language for Automation

- › High speed compiled BASIC programming language for motion and machine control
- › Comprehensive library of motion types including positional moves, cam profiling, flying shears, gearing and more
- › Multitasking capability for motion, I/O, HMI and communication tasks, allows complex applications to be broken down into simpler, more manageable sub-tasks
- › Comprehensive Windows[®] based tools including color keyword highlighting in the editor, software oscilloscope, online help, drive configuration wizard and auto-tuning
- › Modular programming capability, including functions and subroutines, allows for code re-use and ease of debugging
- › ActiveX[®] components (supplied free of charge) aid in the development of Microsoft Windows[®]-based front end applications
- › Common programming interface for both NextMove motion controllers and Baldor's intelligent drives, reduces the learning curve
- › Supported by MintDrive-II, Flex+Drive-II and H2 (via Mint option card)

BASIC – the de-facto Programming Language

With nearly two decades of history, Mint[®] was designed from the outset around the BASIC programming language. It was understood then, and is still true today, that BASIC is the de-facto programming language around the world. Now in its fifth generation, Mint fully embraces all the modern BASIC programming functionality including features such as multitasking, functions and subroutines, data types and local data. This functionality makes it simple to write and develop modular programs that are easily understood by others, easily maintained and easily re-used across different applications. Mint's new Code Library makes code re-use even easier by allowing snippets of code to be stored and used for other projects. This is just one of the many features in the Mint development tool, Mint WorkBench, which are designed to get you up and running quickly.

More than just motion control

Mint excels in motion control applications, but is equally at home in HMI interaction, communications, I/O handling and complex mathematical functions. While some choose a standard 'open' PLC language platform that offers a 'standard' set of motion features, those looking for an edge will find it in the advanced motion capabilities of Mint. Many industries at the cutting edge of motion control realize this and find PLC technology limited in its capabilities for motion control.



Realizing that today's applications are more demanding, more precise, more dynamic and more complex, Mint focuses on providing creative features, advanced motion capabilities and features for the user to innovate in the application solution.

Multitasking Streamlines Program Flow

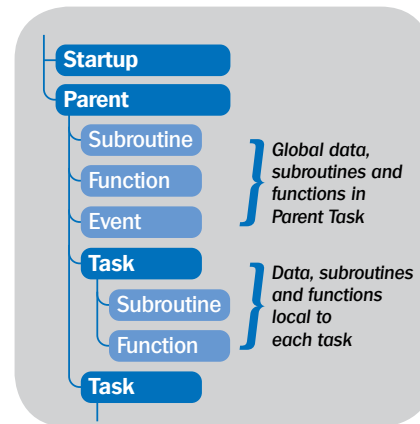

With many devices to control and machine functions to coordinate, it often helps to be able to structure code into specific tasks and allocate them resource dynamically at runtime. Multitasking is one of the key features of Mint. Numerous software tasks can be written, initiated, suspended, terminated and prioritized at will, to optimize workflow and improve machine performance. In its simplest form consider that separate program tasks can be allocated to functions of motion control, HMI interaction, I/O control, communications and much more, producing a structured programming solution and ensuring more dynamic program flow.

Comprehensive Library of Move Types

Move Buffer Enables Continuous Motion

All axes have a flexible and powerful move buffer system that allows multiple move commands to be loaded and then executed. Each entry in the move buffer can contain a unique identifier, independent Speed, Acceleration and Deceleration settings. A configurable *Move buffer low* system event will trigger either a Mint routine or ActiveX service which you can customize to refill the buffers. Output transitions states and pulse times and even dwell times can be loaded into the move buffer to ensure they are synchronous to the axes motion.

Motion Profiles – Positional Moves

Mint offers many flexible move types to suit your application requirements.



Positional Moves (Absolute and Relative): With its own speed, acceleration and deceleration defined (including trapezoidal and S-ramp profiles).



Speed Control: A jogging function allows the motor to run indefinitely at a defined speed, in position control.

Motion Profiles – Master/Follower

Master follower applications can be geared off any of the encoder inputs, Pulse/Direction input or virtual axes.



Electronic Gearbox & Clutch:

Enables two or more shafts to be linked with a programmable ratio. Any axis can be geared to any other axis. Clutch allows precise start and stop distances when synchronizing.



Registration on the Fly: An offset move can be superimposed on the gearing move for position correction. This can be triggered from any of digital inputs or by Mint.



Electronic Cam: Replaces traditional mechanical cams with servo/vector/stepper motor and software programmable profiles (relative or absolute).



Flying Shear: Allows position synchronization of a slave axis to a master, with defined acceleration and deceleration profiles - all linked by software to product movement.

Multi-Axis Motion Control

Multi-axis motion control is supported by Baldor's NextMove family of multi-axis motion controller. In addition to the supported move types above, NextMove can perform multi-axis interpolated motion, tangential knife control, helical interpolation and splining.

Refer to Catalog BR1202-B for further information on the Mint programming language.

Supported Mint Features

	Flex+Drive-II	MintDrive-II	H2 Servo
Multitasking	☐	■	⊙
Speed Control	■	■	⊙
Positional Moves	■	■	⊙
Electronic Gearbox	■	■	⊙
Registration on the Fly	■	■	⊙
Electronic CAM	☐	■	⊙
Flying Shear	☐	■	⊙

- Supported
- ☐ Not Supported
- ⊙ Option (available 2006)

Application Development Tools

Mint WorkBench is a Windows-based application which is common across Baldor's range of servo drives and NextMove motion controllers. Used as a commissioning and set-up tool, the tuning wizard allows you to tune a motor in minutes. Mint WorkBench offers an easy to use development front end for Mint programming, with its color highlighting of keywords and context sensitive help. The Program Navigator makes it a breeze to navigate the source code, no matter how complicated.

Features include:

- › Command line interface to interrogate the drive or motion controller
- › Spy window to monitor common motion variables and I/O
- › Software oscilloscope
- › Watch window for variable and task monitoring
- › SupportMe function with automatic e-mail generation for rapid technical support
- › Web updates of product firmware within Mint WorkBench
- › Easy management of firmware files

Simply click on the function, task or subroutine from within the Program Navigator and you will be taken to the appropriate place in the editor.

Program Editor provides color syntax highlighting for all Mint keywords. Help is just a keystroke away.

Toolbox provides quick access to useful tools

Mint Library can store commonly used routines for use in other projects

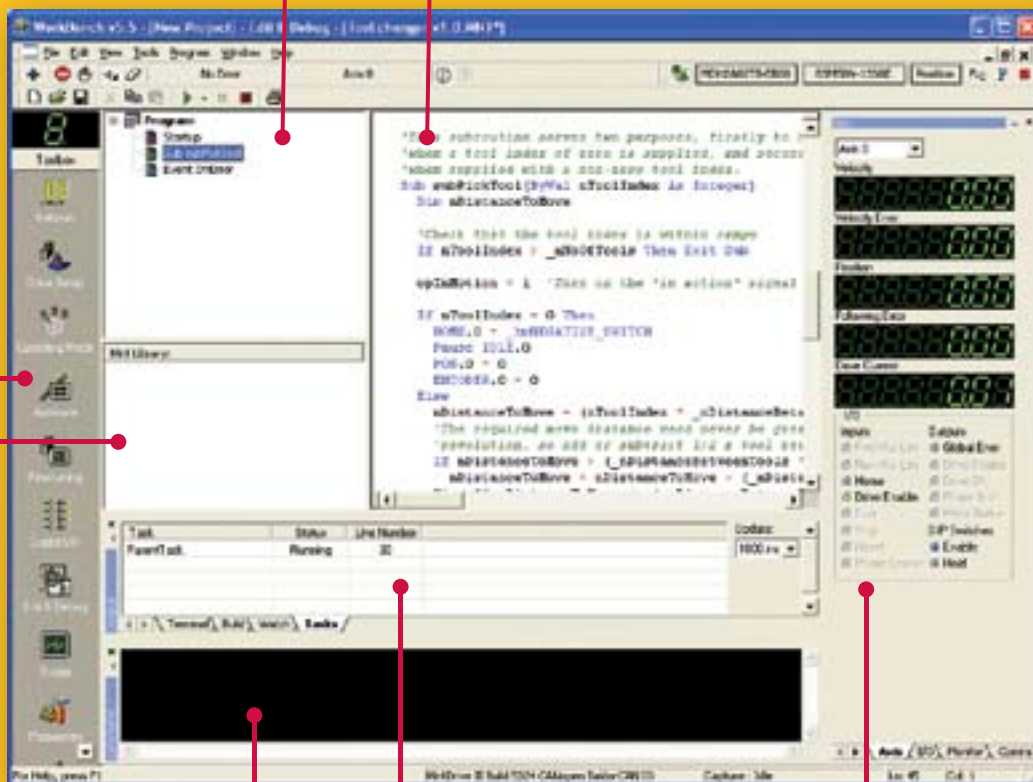

Command line provides access to Mint keywords during program execution and is useful during set-up

The Output window can be configured to show:

- › Terminal output from the controller
- › Program data via the Watch window
- › Compiler errors and warnings

The Spy Window can be configured to show typical information such as axis position or error and can be customized to suit the application. Data can be plotted on the software oscilloscope.

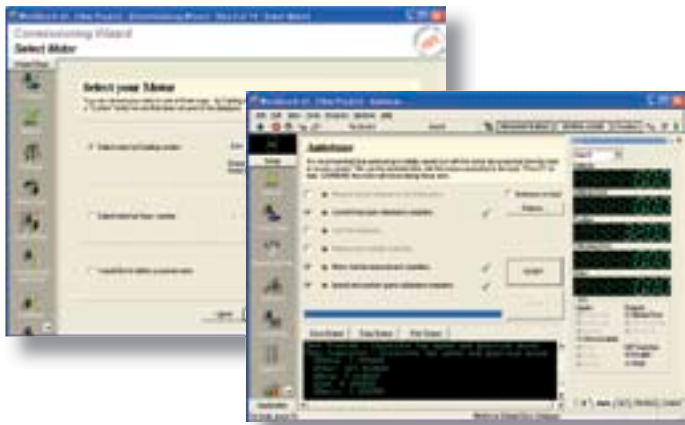

Commissioning Wizard

- › Step-by-Step guide to fully tune current loop, velocity and position
- › User defined units for velocity and position
- › Motor selection from database
- › Automatic selection of drive parameters
- › Automatic detection of U, V and W connections
- › Measurement of system inertia and friction
- › Feedback test

Software Oscilloscope

- › Digital capture of data - up to 6 channels
 - › User configurable color schemes
 - › Save data for future comparison
- New features include:
- › Cursor bars to measure value between two points
 - › Intelligent zoom
 - › Save and overlay

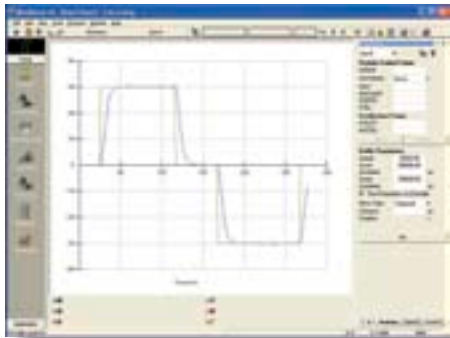

Program Editor

- › Comprehensive editor for creating Mint applications
- › Color syntax highlighting of Mint keywords
- › Hit F1 for online help for any Mint keyword
- › Program Navigator - simply click on the task, function or subroutine to navigate the program.
- › New features provide the ability to re-order your code from within the Program Navigator and save code into the code library

Windows-based Applications with ActiveX

All drives are supplied with ActiveX controls allowing Windows-based applications to be quickly and easily developed. Access is provided to drive parameters for set-up and diagnostics.

The ActiveX controls can be used to provide a simple diagnostics front end through to performing more complex operations such as sequencing motion on a Flex+Drive-II or MintDrive-II. The application programming interface (API) is common with Baldor's NextMove multi-axis motion controller range, helping to cut product development time significantly.



SupportMe

When you need technical support, Mint WorkBench makes this task fast and simple. Using your e-mail, Mint WorkBench automatically collects information on your PC and motion controller or drive for diagnostics. This is sent, including your Mint program, via e-mail to your local support team.

The Mint WorkBench SupportMe function is backed by the SupportMe website (www.Supportme.net), containing all the latest firmware releases, user manuals and more.

MicroFlex e100

ETHERNET Powerlink AC Servo Drive

- › Real-time Ethernet with integrated hub
- › CiA DS402 positioning on ETHERNET Powerlink or CANopen
- › CANopen DS401 network manager for low cost I/O expansion
- › USB port for service / PC based control via ActiveX control
- › Linear and rotary motor control
- › Universal encoder interface
- › 115 – 230 VAC 50/60Hz supply
- › 3, 6 and 9 Amp versions with 200% peak capability



MicroFlex e100 is built on Baldor's expertise in servo drive technology. The advanced capabilities of real-time ETHERNET Powerlink provide superior performance, network integration and cost savings. MicroFlex e100 uses Space Vector Modulation (SVM) for superior motor control and efficiency. Numerous protection features are designed in for reliability and safety.

› Technical Data

Type	MFE230A003	MFE230A006	MFE230A009
Min/Max AC Supply	1 or 3 phase 105 - 230VAC 50/60Hz		
Nominal DC Bus Supply	160 - 325 VDC	160 - 325 VDC	160 - 325 VDC
Cont./Peak Current	3/6 Amps (3 secs)	6/12 Amps (3 secs)	9/18 Amps (3 secs)
Digital Inputs	4 off total - opto-isolated 24V, 1mS sample rate including the following functions: 1 off reserved for drive hardware enable High speed position latch capability for registration applications. $1\mu\text{S}$ latency May be connected positive or negative common for use with NPN or PNP signals Software configurable level/edge triggered an application functions e.g. HOME, LIMIT, STOP		
Digital Outputs	2 off opto-isolated 12-24VDC PNP. 50mA typical per channel, 350mA max load for single channel, 500mA total for 8 channels Software configured functions including Motor Brake control (requires external relay)		
Feedback	Incremental encoders 5V Differential signals. Commutating incremental encoders (with Hall sensors) Hall sensor only for DC trapezoidal control Universal Encoder Interface, supporting - SSI encoders 13 -18 bit single and multi-turn EnDat absolute encoders (v2.1 and v2.2) 1V Peak - Peak Sin/Cos analog encoders with onboard interpolation		
Operating Modes	Profiled Torque (current), Profiled Velocity (speed), Profiled Position - including Homing, Incremental absolute moves etc. Interpolated position mode with Mint motion controllers		

CiA DS402 Positioning Drive Profile

The core architecture of the MicroFlex e100 is based on the CAN in Automation (CiA) DS402 positioning drive profile. This describes the drive behavior (by means of an object dictionary) and provides the ability to perform basic positioning functions such as homing cycles, incremental and absolute moves, change of target position and profiled speed/torque control. This functionality, originally designed for CANopen based control, has been adopted and enhanced for use over ETHERNET Powerlink. The MicroFlex e100 can be controlled over its integrated CANopen port or Ethernet.

CANopen Manager Capability

The Microflex e100 has an integrated CAN port which can be configured to act as a network manager. This provides a convenient and powerful means to expand your system with CANopen I/O devices conforming to CiA DS401 standards. Devices, such as digital and analog input/output modules are managed by the drive, but the I/O states are available to the Mint program running on the NextMove e100, as if they were local to the controller.

Integrated Two Port Ethernet Hub

Connecting multiple devices on the Ethernet network is simplified by an integrated 2 port hub. Simply daisy chain the connection to the next device in the system.

Universal Encoder Interface

A unique feedback interface provides support for leading encoder technology. Incremental encoders (with or without Hall-effect tracks), EnDat 2.1/2.2, SSI single or multi-turn absolute encoders and 1V Sin/Cos encoders, are all supported as standard. This reduces stocking and spares requirements and also ensures the capability to utilize high performance feedback devices for optimum precision, accuracy and smooth speed regulation.

Universal Power Supply for a Global Market

MicroFlex operates from a single or three phase supply, 115 to 230 VAC. The control electronics are maintained by an external customer supplied 24 VDC supply, in the event of main AC power removal. Useful for typical safety schemes.

Digital I/O for Axis Functions

Three digital inputs provide typical drive and motion signals such as home sensor and limit switches. Two of these can be used for high speed registration, capturing position in typically less than 1µs. An additional input provides a hardware enable interlock. Two digital outputs can be configured for functions such as motor brake control and drive ready.

The MicroFlex e100 I/O is available to the NextMove e100 motion controller as though the I/O is local to the NextMove. Limit errors, for example, will call the Mint error handler on the NextMove e100. A position latch on the MicroFlex e100 drive will result in the position latch event being called within the Mint program on the NextMove e100. This greatly simplifies system expansion.



◀ NextMove e100 multi-axis motion controller for control of up to 16 axes of MicroFlex e100 drives.

Refer to catalog BR1202-I for full information on Baldor's real-time Ethernet Solution

Ethernet	Specification: 100Mbit - IEEE802.3u compliant Protocol : ETHERNET Powerlink V2 (EPL) and IP protocols TCP/UDP Interface : Integrated 2 port Hub for daisy chain connection Cable type : CAT5e Shielded cable, RJ45 connectors, Max 100m (330ft) Address: 2 off rotary HEX switches sets node and IP address Function : EPL /CiA DS402 Positioning Drive
CANopen	Single CAN port via standard 9 pin Sub-D connector. CANopen DS301: Manager of CANopen DS401 I/O devices, Master functionality for peer-to-peer communications with other Mint nodes CiA DS402 Positioning drive mode via CANopen (controlled device)
Protection	DC bus over voltage monitoring; DC bus under voltage monitoring; Peak over current; Motor short circuit; Over temperature; I2t over current
Regenerative Capability	Regeneration braking IGBT - requires external regen resistor
Control Supply Input	24VDC nominal (20-30VDC) @ 1A external (4A power on surge) - customer supplied
Connectors	D-type for serial port and feedback. Two part terminals for motor and power
Indicators	1 off LED for drive status/health 2 off LEDs for Ethernet activity 2 off LEDs for CANopen activity
Dimensions	H: 180mm (7.09in) W: 79.6mm (3.13in) L: 157mm (6.18in)
Weight	1.5 Kg (3.3 lbs.)
Operating Temperature	0°C to 45°C

MicroFlex

Brushless AC Servo Drive

- › AC Servo Drive - 3, 6 or 9 Amps
- › Direct 115-230VAC single phase or 3 phase
- › High performance control of brushless AC servo motors - rotary and linear
- › Encoder and 17-bit SSI feedback - software selectable
- › Optional resolver feedback
- › RS232 or RS485 commissioning port
- › Intuitive wizard software - set-up in minutes



The MicroFlex digital servo drive provides a cost effective, high performance solution for your servo drive needs. Incorporating a digital signal processor (DSP) for motor control, MicroFlex supports features such as digital filters to help reduce resonance within the machine.

MicroFlex is ideally matched to Baldor's range of brushless high performance rotary servo motors and linear motors.

MicroFlex is a totally digital drive, utilizing a high performance Digital Signal Processor (DSP) for motor control. A 16KHz Space Vector Modulation (SVM) and 62.5µS current loop update, ensure optimal current regulation and dynamic performance for today's demanding applications.

By controlling the IGBT power devices using SVM instead of the more usual carrier based pulse width modulation (PWM), users can run servo motors at typically 15% higher speeds with reduced switching losses and harmonics. In today's world of increased productivity, this can translate directly into greater machine throughput.

› Technical Data

	FMH2A03TR-xNx3	FMH2A06TR-xNx3	FMH2A09TR-xNx3
Min/Max AC Supply	1 or 3 phase 105 - 230VAC 50/60Hz		
Nominal DC Bus Supply	160 - 325 VDC	160 - 325 VDC	160 - 325 VDC
Cont./Peak Current	3/6 Amps (3 secs)	6/12 Amps (3 secs)	9/18 Amps (3 secs)
Digital Inputs	Two Inputs: Enable, Reset (software configurable) - Opto-isolated (10-30VDC)		
Digital Outputs	One Output: Drive OK - opto-isolated		
Analog Command Input	±10V with 12-bit ADC resolution. Programmable for torque or velocity command		
Step and Direction Input	Single ended 5V TTL 400MHz maximum frequency		
Feedback	Digital interface programmable for: - Incremental encoder with encoder loss detection. Max. frequency 10 MHz - Commutating incremental encoder - 17-bit synchronous serial interface (SSI) with 7 wire interface - Hall sensor (no encoder) for trapezoidal commutation Optional resolver feedback interface.		

Compact Package

Housed in a compact package, MicroFlex is available in 3, 6 and 9A versions (with 200% overload). All current ratings share the same dimensions, making panel design simple for different application demands. Voltage operation is from 115 through 230VAC single or three phase, making MicroFlex ideal for international markets.

Industry Standard Interface

The industry standard $\pm 10V$ analog command input can be configured for either a torque or velocity reference. Alternatively, an integrated TTL Step and Direction interface makes MicroFlex the ideal package for stepper drive upgrade in both new and retrofit applications. This can even be used to expand the number of servo axes when used with Baldor's NextMove controllers and their stepper interfaces.

MicroFlex supports a software configurable encoder interface supporting: commutating encoders; Hall-effects and synchronous serial interface (SSI). Resolver is supported as an option.

An encoder output interfaces directly to the motion controller or PLC for position and velocity update.

Easy Set-up

Set-up is performed from a simple wizard driven front end from within the Mint WorkBench. Standard Baldor motors are selected from a drop-down. For custom motors, the front end can calculate key parameters such as motor inductance, resistance and inertia. Only the simplest of data needs to be entered keeping set-up time to a minimum. The auto-tune process will even detect incorrect wiring of the motor and feedback and electronically correct for them.

Reliable Design

To ensure reliability, MicroFlex protects against: over speed; over voltage; over current; feedback loss and motor I^2t .

Drive Diagnostics

The multi-drop RS485 network can be used for drive diagnostics allowing the host controller such as NextMove or a PLC to interrogate the drive in the event of an error.



The optional footmount EMC filter saves panel space. Provision is made to accommodate the optional fan tray. The fan tray provides forced air cooling for larger power sizes (> 3A RMS current).

Encoder Output	Simulated encoder output for connection to external motion controller
Commutation	Sinusoidal commutation with resolver, encoder or SSI feedback Trapezoidal commutation with Hall sensors only
Modes of Operation	Torque control, velocity control or step and direction
Communications	RS232 or RS485 for commissioning and diagnostics
Protection	DC bus over voltage monitoring; DC bus under voltage monitoring; Peak over current; Motor short circuit; Over temperature; I^2t over current
Regenerative Capability	Regeneration braking IGBT - requires external regen resistor
Control Supply Input	24VDC nominal (20-30VDC) @ 2A external (4A power on surge) - customer supplied
Connectors	D-type for serial port and feedback. Two part terminals for motor and power
Indicators	Single LED indicator for drive status
Dimensions	H: 180mm (7.09in) W: 79.6mm (3.13in) L: 157mm (6.18in)
Weight	1.5 Kg (3.3 lbs.)
Operating Temperature	0°C to 45°C

H2™ Servo Drive

- › Industrial enclosure
- › 3 to 54 Amp - Three phase 200-240VAC
- › 3 to 27 Amp - Three phase 380-480VAC
- › Single phase operation 115 or 230VAC
- › Easy to use keypad for setup and diagnostics
- › USB port for service
- › Linear and rotary motor control
- › Feedback options including encoder and resolver
- › Field pluggable option cards



The H2 Servo Drive builds on the success of the H-Series drives, with a harmonized keypad, common across different motor technologies - servo and induction motors. Housed in an industrial enclosure, H2 provides a robust and trouble free installation.

Unparalleled Ease of Use

Baldor's H-series drives are universally acclaimed for their ease of use. Our new H2 drives are designed to be even easier to use. At the heart of H2 is a new keypad with 128 x 64 pixel graphical display which allows even more information to be displayed on the screen at any one time.

Help Easily to Hand

Every screen displayed on the keypad has help text available to aid the user. Simply press the help key to view the help text.

Common User Interface

The removable keypad is interchangeable, interfacing with all H2 power bases, regardless of technology. The keypad screen displays the operating conditions and the programming steps in easy to follow text, eliminating the need to look up parameters or program the wrong settings.

I/O for Machine Control

On board I/O provides machine control function and allows interfacing to external logic devices such as a PLC or motion controller. A number of preset operating modes are available, including preset positions and speeds.

› Technical Data

Min/Max AC Supply	180 - 264 VAC 3 Phase 50/60Hz, 340 - 528 VAC 3 Phase 50/60Hz 115 or 230VAC ±10% single phase 50/60Hz
Cont./Peak Current	3 to 54 Amps (180 - 264 VAC) 200% overload at 3 secs 3 to 27 Amps (340 - 528 VAC)
Digital Inputs	8 off opto-isolated 12-24VDC. Configured through the keypad
Digital Outputs	2 off opto-isolated 12-24VDC
Relay Outputs	2 off configured through the keypad
Analog Command Input	±10V with 12-bit ADC resolution. Programmable for torque or velocity command Additional analog input for general use.
Step and Direction Input	Option board
Feedback	Option of resolver or encoder input Commutating incremental encoder with encoder loss detection. Max. frequency 10 MHz Hall sensor (no encoder) for trapezoidal commutation
Encoder Output	Simulated encoder output for connection to external motion controller when used with resolver feedback.
Commutation	Sinusoidal commutation with resolver or encoder Trapezoidal commutation with Hall sensors only

Simple to Program and Operate

Navigation keys make H2 extremely easy to use, allowing complete, full function navigation. Familiar up and down keys along with left and right arrows navigate effortlessly through the display and programming functions.



Parameter Save and Copy

If several drives need to be programmed, the keypad can save all the control parameters from one drive and copy those parameters into another drive. Up to 4 parameters tables are supported by one keypad.

Common Programming Tools

The H2 family of drives (servo, vector, encoderless and inverter) all share the same identical operator keypad, field installed options, programming style and operating modes. Baldor have now introduced Windows-based commissioning with the Mint WorkBench, a program common with Baldor's range of servo drives and multi-axis motion controllers.

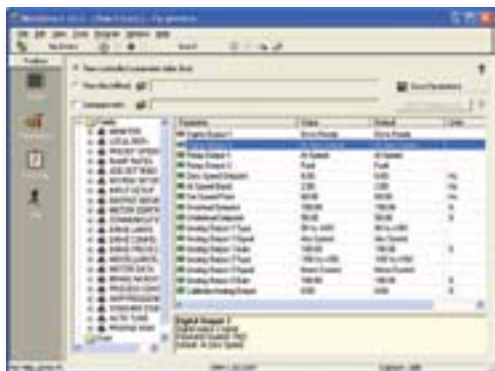

Bus Communication Expansion Boards

The ability to communicate is important in industrial automation and even more important in the areas of drives and process control. Baldor H2 drives offer a variety of optional plug-in expansion boards that connect directly to several popular PLC and building automation networks including: DeviceNet, Ethernet IP, Profibus DP, and Lonworks.

As a standard feature, the H2 drives include a Modbus RTU communications port. If you need your drives to communicate to cells of larger machines, or large building automation networks, the Baldor H2 drive family can do the talking...and listening too!

Flexible Options

The H2 Servo Drive supports up to 2 option cards. The following options are available:

Ethernet Server Board: Allows remote monitoring from a standard web browser. No additional software is required since the drive acts as a server to build HTML pages on your desktop computer screen.

Master Pulse Reference/Pulse Follower: Can be used for following applications, with a software gear ratio. The inputs can be configured for incremental encoder or pulse and direction.

High Resolution Input: Provides 16-bit analog input resolution. Inputs are selectable for ±10 VDC, 0-10 VDC and 4-20 mA.

Mint Motion Module: Provides complete Mint programming capability for high performance applications. Multitasking Mint is supported with moves types such as indexing moves, cam profiles, software gearboxes and flying shears.

Fieldbus Options: Various fieldbus options are available including DeviceNet, Profibus-DP and LonWorks. Modbus-RTU is available as standard on H2.

Refer to catalog BR702 for full information on Baldor's H2 Product Range

Modes of Operation	Torque control, velocity control or preset positions. I/O modes programmable through keypad
Communications	USB 2.0 port for PC communications. Modbus RTU port
Protection	DC bus over voltage monitoring; DC bus under voltage monitoring; Peak over current; Motor short circuit; Over temperature; I ² t over current
Regenerative Capability	Internal braking resistor
Control Supply Input	24VDC internally generated
Connectors	Two part screw terminal connectors for I/O Screw terminal connectors for power and feedback
Keypad	14 key membrane with tactile response. Rated to IP65 LED status indicators on Jog, Rev, Fwd and Stop. Backlit LCD 128 x 64 graphical display IP67 (NEMA 4X) rated. Can be mounted up to 30.5m (100 ft) from the drive Includes drive parameter storage - 4 parameter sets supported
Dimensions	See page 26
Weight	See page 26
Operating Temperature	-10°C to 45°C @ 90% max relative humidity
Approvals	CE, UL, cUL

EuroFlex

Rack Mount AC Servo Drive

- › **Brushless AC Drive - 5 Amps continuous, 15A peak**
- › **18-56 VAC input**
- › **EuroCard 3U rack mounted module**
- › **Sinusoidal commutation with encoder feedback**
- › **RS485 port for commissioning and diagnostics. RS232 optional**
- › **Ideally matched to Baldor's NextMove ES motion controller**



EuroFlex is a compact rack mounted servo amplifier, ideally matched to Baldor's NextMove ES motion controller and range of cog free linear servo motors. Operating over a 18—56 VAC (25—80 VDC) bus, EuroFlex is ideally suited to low voltage applications such as in the medical and semi-conductor sectors.

Rack Mount Solution

EuroFlex is suited to Baldor's multi-axis motion controller, NextMove ES, a rack mount card. Both cards are single EuroCard in length (160mm). NextMove ES can control up to 2 axes of servo, plus a further 4 stepper axes.



▲ NextMove ES multi-axis motion controller

› Technical Data

Min/Max AC Supply	1 or 3 phase 18-56 VAC 50/60Hz or 25-80 VDC
Nominal DC Bus Supply	25-80 VDC
Cont./Peak Current	5/15 Amps (3 secs)
Digital Inputs	Two Inputs: Enable, Reset (software configurable) - Opto-isolated (10-30VDC)
Digital Outputs	One Output: Drive OK - opto-isolated
Analog Command Input	±10V with 12-bit ADC resolution. Programmable for torque or velocity command
Step and Direction Input	Single ended 5V TTL. 400MHz maximum frequency
Feedback	Commutating incremental encoder with encoder loss detection. Max. frequency 10 MHz Hall sensor (no encoder) for trapezoidal commutation
Encoder Output	Simulated encoder output for connection to external motion controller
Commutation	Sinusoidal commutation encoder Trapezoidal commutation with Hall sensors only
Modes of Operation	Torque control, velocity control or step and direction
Communications	Multi-drop RS485 for commissioning and diagnostics. RS232 optional

Industry Standard Interface

Using the industry standard ± 10 V input command signal, EuroFlex may be configured to operate in torque or velocity mode. A step and direction input makes EuroFlex an ideal replacement for stepper based applications that require higher speed or more torque.

EuroFlex supports standard commutating encoder feedback for the control of linear or rotary servo motors. An encoder output channel allows the EuroFlex to interface to a motion controller, such as Baldor's NextMove range of Mint programmable motion controllers or a PLC.

Simple Set-up

Mint WorkBench provides full auto-tuning capabilities and diagnostics. Additional software features include advanced Low-Pass and Notch frequency filters. These help in eliminating the affects of resonant frequencies which can effect performance. This in turn allows for stiffer control of the mechanical system, which can ultimately improve throughput.

Different Gain Settings Handled with Ease

Up to 4 different gain settings can be stored in the drive. These can be selected from two binary inputs on the backplane connector. This allows easy swapping of drives, where different gain terms may be used for different axes.

Optional Backplane

All connections are brought out via a DIN41612 Type M connector. A backplane with pluggable screw terminated connectors and D-type connectors is available as an option.

RS485/232 Programming Port

An RS485 port is available for communications, setup and diagnostics. An optional RS232 port is also available.



The optional backplane provides easy connection to control signals. I/O is brought out on to two part screw terminals and encoder signals on to D-type connectors.

Pre-made cables are available from Baldor for connection to the motion controller and drive and the drive and motor.

Protection	DC bus over voltage monitoring; DC bus under voltage monitoring; Peak over current; Motor short circuit; Over temperature; I2t over current
Regenerative Capability	Regeneration braking IGBT - requires external regen resistor
Control Supply Input	24VDC nominal (20-30VDC) @ 2A external (4A power on surge) - customer supplied
Connectors	DIN41612 Type M for all I/O connections for connection to backplane Optional backplane available
Indicators	Three LED indicators for status and health
Dimensions	Standard EuroCard - 3U height H: 100mm (3.9in) W: 55mm (2.2in) L: 160mm (6.3in) Backplane dimensions: H: 100mm (3.9in) W: 130mm (5.1in)
Weight	0.47 Kg (1.0 lb.)
Operating Temperature	0°C to 45°C
Approvals	CE, UL, cUL

Series-II Drives

Flexible AC Servo Drive Range

- › AC servo drive for control of rotary and linear servo motors
- › Single phase to 7.5A
- › Three phase to 27.5A
- › Choice of feedback options: resolver, encoder and EnDat absolute encoder
- › Choice of fieldbus options: CANopen, DeviceNet and Profibus-DP
- › Intuitive Windows-based front end for easy setup
- › Indexing capability with Flex+Drive-II and MintDrive-II
- › Mint programmable Flex+Drive-II



The Series-II AC servo drives are a flexible and versatile range to suit every application whether this is a simple analog command drive, or a sophisticated single axis motion control. The drives share a common Windows-based user front end, options and connector pin-outs making the products easily interchangeable for different application requirements.

FlexDrive-II

FlexDrive-II offers a simple, easy to set-up AC servo drive, using the intuitive Windows-based Mint WorkBench.

FlexDrive-II provides fully programmable I/O for interfacing to external I/O. From the PLC set-up screen in Mint WorkBench, different conditions can be programmed for the I/O. 16 preset speeds are supported which can be easily selected from the onboard I/O.

Flex+Drive-II

The Flex+Drive-II is a flexible indexing drive offering 16 preset positions or speeds that are setup from a simple Windows based table driven interface. Each move can have its own speed, acceleration and deceleration setting. Moves are initiated using the onboard digital inputs, from an external device such as a PLC. An optional I/O card expands the number of pre-set positions to 256.

Flex+Drive-II is more than just an indexer. For more complex applications, Flex+Drive-II is programmable in a single tasking version of Baldor's Mint motion programming language.

MintDrive-II

The award winning MintDrive-II offers the best in flexibility, integrating a powerful motion controller and AC servo drive into a compact package. Programmable in Baldor's multitasking Mint motion software, and with onboard I/O, MintDrive-II can become a single axis machine controller, handling motion, PLC and

HMI tasks with ease. Compatible with Baldor's range of multi-axis motion controllers, Mint provides support for move types such as positional moves, electronic cams, flying shears and software gearboxes with positional offsets.



Fieldbus Options

The drives are available with factory fit options for different fieldbusses. Access to many of the Mint keywords is available over the fieldbus network. For example, a move can be initiated over the Profibus-DP network to a Flex+Drive-II.

Option C: CANopen

- › CANopen implementation according to CiA DS301 specification.
- › Allows communication between the servo drive and a Baldor HMI panel.
- › MintDrive-II can be configured as a manager node providing access to DS401 I/O devices such as digital and analog I/O.
- › Peer-to-peer networking supported between devices. A NextMove motion controller or MintDrive-II can act as network master.

Option B: CAN and I/O

- › Provides CANopen support as Option C above.
- › Digital I/O expansion via 25-pin D-type: 10 digital inputs (12-24VDC PNP/NPN opto-isolated) and 5 digital outputs (12-24VDC PNP opto-isolated). Expands preset positions to 256.
- › Dual CAN support for MintDrive-II. Baldor CAN supported on second CAN channel for control of Baldor CAN I/O devices.
- › Single CAN support for Flex+Drive-II.

Option D: DeviceNet

- › Slave only implementation.
- › Provides access to Mint keywords to initiate motion and for diagnostics.
- › Fault and position indicators sent via process data.
- › Maximum of 63 nodes possible over the network.

Option P: Profibus-DP

- › DP slave implementation.
- › Default and Custom process data definitions.
- › Provides access to Mint keywords to initiate motion and for diagnostics.
- › Access to local drive I/O states.
- › Up to 12 MBaud network speed.
- › Simple 2 wire multi-drop cabling system with standard 9-pin D-shell connection.

› Series-II Product Selector

	FlexDrive-II	Flex+Drive-II	MintDrive-II	
Drive Characteristics				
±10V command reference	■	■	■	
Pulse and Direction Input (5V and 24V)	■	■	■	
Resolver	■	■	■	
Encoder	■	■	■	
Absolute Encoder (EnDat)	■	■	■	
Auto-tune of current, velocity and position loop	■	■	■	
Position latch for high speed registration	□	■	■	
Programming				
Mint program support	□	■	■	
Multitasking	□	□	■	
Programmable I/O	■	■	■	
Table driven PLC task for user defined operations	■	■	■	
16/256 preset positions and speeds	■ Speed only	■	■	
Program Size	□	64kB	128kB	
Non-volatile user parameter storage	□	□	8kB	
ActiveX control for Windows based applications	■	■	■	
Move Types				
Logging	■	■	■	
Absolute and relative positional moves	□	■	■	
Homing	□	■	■	
Gearing from master encoder with programmable gear ratio	■	■	■	
Gearing with positional offset (for on the fly registration)	□	■	■	
CAM profiling	□	□	■	
Flying shears	□	□	■	
Gearing with defined clutch distance	□	□	■	
Options				
CANopen master for peer-to-peer networking	□	□	○	
CANopen master for control of third party I/O devices	□	□	○	
CANopen slave	○	○	○	
DeviceNet Slave	○	○	○	
Profibus-DP Slave	○	○	○	
I/O Expansion (10 digital inputs + 5 digital outputs)	□	○	○	

■ Supported
 □ Not Supported
 ○ Option

FlexDrive-II

Flex+Drive-II

Brushless AC Servo Drive

- › Flexible and versatile drive range
- › RS232/485 serial port for commissioning or connection to external PLC
- › Programmable I/O capability
- › Choice of simple drive with the FlexDrive-II or indexing capability with the Flex+Drive-II
- › Mint programmable capability (single task) with Flex+Drive-II



FlexDrive-II is a flexible servo drive for the control of both rotary servo motors and linear motors. FlexDrive-II can accept the industry standard $\pm 10V$ analog input, pulse and direction for stepper replacement applications, or electronic handwheel for simple gearing.

Flex+Drive-II extends the capability of FlexDrive-II with the ability to perform point-to-point moves, initiated from the onboard I/O. Further flexibility is provided with its onboard Mint programming capability.

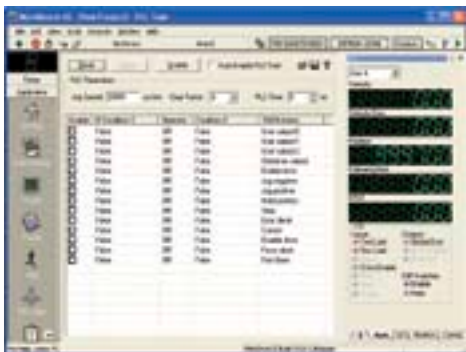

▲ Windows based table driven user interface allows simple logic to be configured for interfacing to an external device such as a PLC

Configurable I/O

The onboard I/O of both FlexDrive-II and Flex+Drive-II can be programmed from the Mint WorkBench using a table driven user interface. This provides an easy interface to an external device such as a PLC. Up to two conditions can be combined using different logical operators to provide an output action. This can include setting or clearing any of the 3 digital outputs, forcing the drive into a particular state or even jogging the motor at a predefined speed.

Flexible Drive Command Input

An industry standard $\pm 10V$ analog input provides either a torque or velocity control signal. The input can be programmed for $\pm 10V$, 0-10V with direction or $\pm 5V$. Alternatively, the drives can be setup in a gearing mode following the onboard master encoder at a predefined gear ratio. The master encoder can be configured for quadrature input or 5V step and direction. A 24V step and direction input can also be used on this mode to provide the ultimate flexibility.

Flexible Drive Family

FlexDrive-II and Flex+Drive-II offer a flexible solution to suit your application needs. Optional fieldbuses (CANopen, DeviceNet and Profibus-DP) provide powerful connections to industry leading programmable logic controllers (PLCs).

Fieldbus solutions provide access to the Mint command set allowing complete interrogation of the drive for both diagnostics and commissioning.

For indexing applications, the Flex+Drive-II offers a powerful solution. Moves can be set up in Mint WorkBench and initiated using the I/O. Alternatively move commands can be sent over any of the available fieldbus options.

For more complex applications, Flex+Drive-II can be networked with MintDrive-II over the optional CANopen interface. This provides full peer-to-peer networking, allowing drives to communicate with each other over the network. This can be used for coordinated motion, downloading recipes or diagnostics.

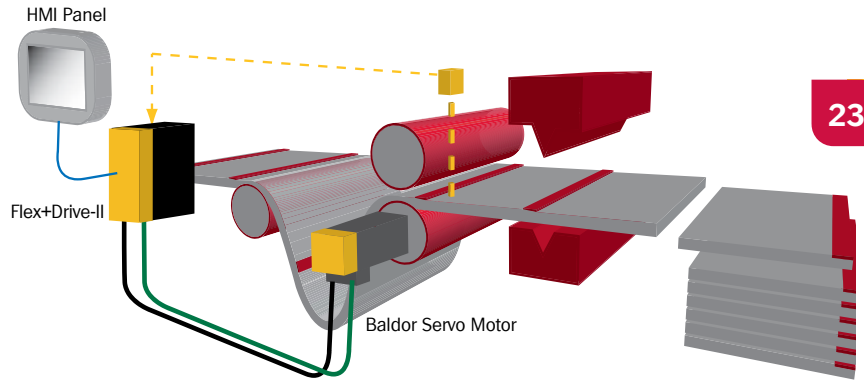

▲ Flex+Drive-II provides the power and flexibility to act as a single axis machine controllers for applications such as cut to length and other indexing requirements. An HMI can interface with the drive over the RS232/485 port and be used for recipe data, machine configuration or diagnostics.

Simple and Sophisticated Point-to-Point Moves

Flex+Drive-II provides the capability to handle point-to-point (index) moves with ease. Move data can be loaded via Mint WorkBench using a simple table driven user interface. Up to 16 preset positions can be loaded, with data including absolute/relative position, speed, acceleration and deceleration. Using the onboard I/O, requests to new positions are controlled using 4 digital inputs. Full handshaking with the external host (such as a PLC) is handled over the I/O. In addition to the preset positions, preset speeds can be loaded. A home position and home sequence can also be defined.

I/O Expansion

The number of preset positions can be expanded using the CAN + I/O (Option B) option card. This adds a further 10 digital inputs and 5 digital outputs. Up to 256 pre-set positions can be loaded. The preset positions are broken down into groups of 16 positions, each group having their own speed, acceleration and deceleration.



▲ Position and speed table for 16 presets (expandable to 256 with I/O option card)



▲ Mint programming capability for more complex indexing applications

MintDrive-II

Servo Drive with Integrated Motion Controller

- › **Features of Flex+Drive-II plus:**
- › **Multitasking Mint capability**
- › **Comprehensive library of move types including CAMs, flying shears and software gearboxes**
- › **Onboard non-volatile RAM for recipe data**
- › **CANopen network master capability with optional card**
- › **Two analog inputs and two analog outputs**



The award winning MintDrive-II offers the best in flexibility, integrating a powerful motion controller and AC servo drive into a compact package. Programmable in Baldor's multitasking Mint motion software, and with onboard I/O, MintDrive-II can become a single axis machine controller, handling motion, PLC and HMI tasks with ease. Compatible with Baldor's range of multi-axis motion controllers, Mint provides support for move types such as:

- › Indexing moves - absolute and relative
- › CAM profiling
- › Software gearing with positional offsets
- › Flying shears
- › Speed control



Flexible Programming

Flexible programming is provided by means of Mint and the Mint WorkBench. Fully compatible with Baldor's NextMove range of multi-axis motion controllers, Mint provides unrivalled flexibility and ease of use. Full access is provided to the onboard I/O for complete PLC tasks. I/O is easily expanded by means of the optional CAN+I/O board.

CANopen Master for Flexible Networking

MintDrive-II is available with a CANopen option providing a flexible networking solution. Acting as a network manager, the MintDrive-II can operate any third party digital I/O conforming to the CAN in Automation (CiA) DS401 I/O profile. In addition, multiple MintDrive-II's and other Mint controllers such as NextMove and Flex+Drive-II can be linked on the same CANopen network. Data can be passed between Mint applications running on each node. This makes it easy to develop distributed control systems.

High Speed Position Latching

MintDrive-II's ability to capture position in real-time makes it ideal for applications such as labeling, cutting on the fly and positioning on the fly, where the exact position of a product is required.

Series-II Technical Data

	FlexDrive-II	Flex+Drive-II	MintDrive-II
Min/Max AC Supply	115VAC Single Phase 230VAC Single Phase 230 - 460VAC 3 Phase		
Nominal DC Bus Supply	160 VDC (115 VAC 1 ϕ input) 320 VDC (230 VAC 1 ϕ input) 325 VDC (230 VAC 3 ϕ input) / 650 VDC (460 VAC 3 ϕ input)		
Cont./Peak Current	2.5, 5.0, 7.5 Amp Single Phase with 200% peak for 2.8s (2.5A, 5A), 1.2s (7.5A) 15A 230VAC Three Phase with 200% peak for 1.2s 2.5, 5.0, 7.5, 15, 20, 27.5 Amp Three Phase with 200% peak for 1.2s		
Control Logic Supply	Optional for single phase drives. Customer Supplied (see BR1202-H for details on 24V supplies) 24VDC @ 1.75A. Power on surge of 4A for 100ms		
I/O Supply	Customer Supplied 24VDC		
Digital Inputs	8 Opto-isolated (10-30VDC) PNP plus drive enable Software configurable for forward and reverse limits, home, stop and drive error. Programmable logic via Mint WorkBench		
Digital Outputs	3 opto-isolated 24V PNP. Software configurable. 50mA per channel, 350mA max source per channel. 500mA max for 3 channels		
Relay Output	Fault Output. Normally closed. 1A @ 30VDC or 0.5A at 125VAC. Software configurable		
Analog Command Input	$\pm 10V$, 0-10V (with direction), $\pm 5V$, with 14-bit ADC resolution. Torque or velocity command		
Analog Inputs	1x 14-bit	1x 14-bit	2x 14-bit
Analog Outputs	0	0	2x - 8-bit
Encoder Output	Simulated encoder output for connection to external motion controller		
Master Encoder Input	One channel for synchronization and following applications Incremental encoder: RS422 differential AB signals with index (Z) pulse. Can be configured for 5V pulse and direction. 1.25MHz max frequency		
Commutation	Sinusoidal commutation with resolver, encoder or EnDat feedback Trapezoidal commutation with Hall sensors only		
Modes of Operation	Torque control, velocity control, step and direction or position (Flex+Drive-II and MintDrive-II)		
Protection	DC bus over voltage monitoring; DC bus under voltage monitoring; Peak over current; Motor short circuit; Over temperature; I ² t over current		
Regenerative Capability	Regeneration braking IGBT - requires external regen resistor		
Serial Ports	User selectable via DIP switches for RS232 or RS485 communications. RS232 - max Baud rate 57,600 RS485 - max Baud rate 57,600. 32 devices supported on multi-drop network		
Connectors	D-type for serial port and feedback. Two part screw terminals for motor, power and I/O		
Indicators	7-segment display for drive status		
Dimensions & Weights	See page 26		
Operating Temperature	0°C to 40°C (Above derate 2.5%/°C to max 50°C)		
Humidity	10 to 90 non-condensing		
Shock & Vibration	1G - 10-60Hz		
	FlexDrive-II	Flex+Drive-II	MintDrive-II
Fieldbus Options			
CANopen Master	□	□	⊙
CANopen Slave	⊙	⊙	⊙
DeviceNet slave	⊙	⊙	⊙
Profibus-DP slave	⊙	⊙	⊙
Mint Programming			
Mint Programmable	□	Single Task	Multitasking
Indexing Capabilities	□	■	■
Program Memory	-	64K	128K
Non-volatile memory	-	-	8K

■ Supported □ Not Supported ⊙ Option

Dimensions

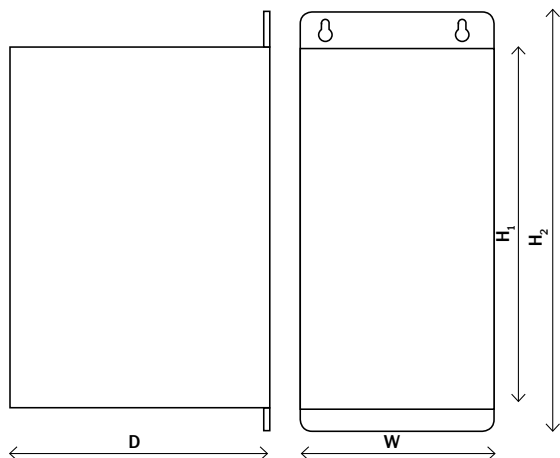

Package Size	Description	W mm (in)	H ₁ mm (in)	H ₂ mm (in)	D ① mm (in)	Weight Kg (Lbs)
FlexDrive-II, Flex+Drive-II, MintDrive-II						
A	2.5A Single Phase. No Option	67.5 (2.66)	173 (6.81)	205 (8.07)	152 (6.0)	1.25 (2.76) ②
B	2.5A Single Phase. Option fitted	84 (3.31)	173 (6.81)	205 (8.07)	152 (6.0)	1.55 (3.42) ②
C	5A Single Phase. No Option	92.5 (3.64)	173 (6.81)	205 (8.07)	152 (6.0)	2.1 (4.63) ②
D	5A Single Phase. Option fitted					
	7.5A Single Phase	109 (4.29)	173 (6.81)	205 (8.07)	152 (6.0)	2.3 (5.07) ②
E	15A 230VAC Three Phase	55 (2.17)	357 (14.06)	400 (15.75)	262 (10.31)	4.9 (10.8) ②
G	2.5 to 7.5A Three Phase	65 (2.56)	357 (14.06)	400 (15.75)	262 (10.31)	4.9 (10.8) ②
H	15 to 27.5A Three Phase	130 (5.12)	357 (14.06)	400 (15.75)	262 (10.31)	9.05 (19.95) ②
MicroFlex, MicroFlex e100						
-	3, 6 and 9A	80 (3.15)	180 (7.09) ③	180 (7.09) ③	157 (6.18)	1.5 (3.3)

① Depth (D) does not take into account connectors and bend radius of cables. Allow approximately 50mm (1.97in)

② Allow 0.3Kg (0.66 Lbs) for option card, if installed.

③ Allow 55mm (2.17in) for optional fan tray.

H2 Servo

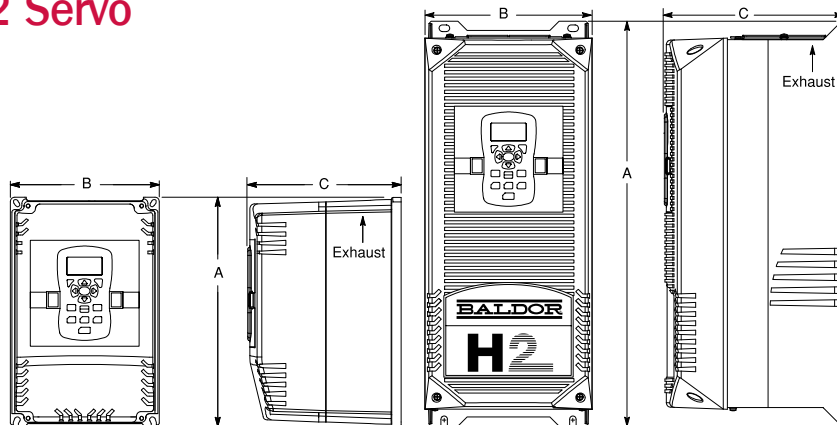

Size AA

Size B and C

Package Size	A mm (in)	B mm (in)	C mm (in)	Weight Kg (Lbs)
AA	311 (12.27)	202 (7.97)	208 (8.21)	
B	457 (18.0)	231 (9.1)	241 (9.48)	
C	559 (22.0)	231 (9.1)	248 (9.77)	

› Accessories

HMI Panels

Refer to catalog BR1202-H for full information.

Baldor's range of programmable HMI panels offers everything from simple text displays through to large color touch screen panels.

- › Text displays from 4x20 character displays to 8x40 with keyboard entry
- › Touch screen displays from mono 3.8" to color TFT 12.1"

All displays are programmable with an easy to use Windows-based front end, removing the burden of handling the HMI task from the motion controller. Communications to the drive or NextMove controller is via serial or CANopen communications.



CAN I/O Modules

CAN I/O modules are available to expand the MintDrive-II's digital I/O. These devices are available in DIN rail format for easy mounting within the machine. Operating over the Baldor CAN protocol*, Mint has full control over the setting and reading of the digital I/O points.

CAN Expansion 8 Digital Inputs

- › 8 Digital opto-isolated inputs
- › 12-24V PNP/NPN operation



CAN Expansion 8 Digital Outputs

- › 8 Digital opto-isolated outputs
- › PNP operation
- › 50mA source on all channels
- › 500mA max outputs for 8 channels



CAN Expansion 8 Relay Outputs

- › 8 relay outputs
- › Form C (SPDT) relays rated at 0.5A @ 125VAC, 2A @ 30VDC



CAN Expansion 24 Inputs, 24 Outputs

- › 24 opto-isolated inputs (PNP/NPN)
- › 24 opto-isolated outputs (PNP)



* Bus Option B must be fitted to the MintDrive-II. This provides both a CANopen and Baldor CAN channel.

Cables

A range of cables, both pre-made and raw, are available to match the drive to Baldor's motor range. Available in different lengths, the pre-made cables are fitted with appropriate connectors at both ends, reducing set-up time and costs.



Refer to catalog BR1202-H for full information.

Power Supply Units

Baldor offers a range of 24V power supply units (PSU) that are ideal for powering the control electronics of the Baldor servo drives, NextMove controllers and HMI panels. With a universal 110-240 VAC input, the PSU's are available with current ratings of 3.2A (75W), 5A (120W) and 10A (240W).



Refer to catalog BR1202-H for full information.

Encoder Splitter Boards

Baldor encoder splitter boards take a single encoder input signal (typically from a master encoder) and splits the signal to multiple drives or motion controllers.



Ordering Information

Series-II: FlexDrive, Flex+Drive, MintDrive

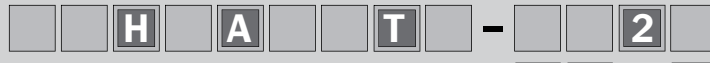

Drive Family

MDH = MintDrive-II
 FPH = Flex+Drive-II
 FDH = FlexDrive-II

Input Voltage

1 = 115VAC 1 ϕ
 2 = 230VAC 1 ϕ / 230VAC 3 ϕ ⑥
 4 = 230-460VAC 3 ϕ

Current Code

A02 = 2.5 Amps
 A05 = 5 Amps
 A07 = 7.5 Amps
 A15 = 15 Amps
 A20 = 20 Amps
 A27 = 27 Amps } 3 ϕ only

Braking Options ④

R = Requires external resistor
 B = Built in regen resistor

Logic Supply

0 = Internally generated ①
 3 = External customer supplied +24 VDC

Bus Options ⑤

N = None
 B = Dual CAN + Extra I/O ②
 C = CANopen
 D = DeviceNet
 P = Profibus-DP

Feedback Options

R = Resolver
 E = Encoder
 D = Absolute Encoder (EnDat) ③



Notes

- ① Only available on single phase drives. Option 3 is recommended for Flex+Drive and MintDrive to maintain position during machine stop conditions
- ② Only provides CANopen and I/O on Flex+Drive-II. Not supported on FlexDrive-II
- ③ Limited support on FlexDrive-II
- ④ Select B for 2.5 and 5.0A drives
 2.5A models have internal 20W 175 ohm (single phase) or 300W 200 ohm (3 phase) regen resistor
 5.0A models have internal 20W 175 ohm (single phase) or 300W 200 ohm (3 phase) regen resistor
 Select R for all other drives
- ⑤ May increase width of drive. See Page 26
- ⑥ 230VAC 3 phase drive available in 15A variant only. Specify FDH2A15TR-RN23 for example.

Example Catalog Numbers:

FDH2A05TB-RN23 - FlexDrive 230VAC single phase, 5A, resolver feedback, external 24V. No options.

FPH2A15TR-ED23 - Flex+Drive 230VAC 3 phase, 15A, encoder feedback, external 24V, DeviceNet option.

MDH4A15TR-EB23 - MintDrive 460VAC, 15A, encoder feedback, external 24V, CANopen + I/O option.

Auxiliary I/O Breakout Board

For use with Bus Option B. Provides screw terminal connectors for I/O.

Catalog Number	Description
OPT017-501	Auxiliary I/O breakout board
CBL022-502	Auxiliary I/O breakout board cable 2m (6ft)

MicroFlex and MicroFlex e100



Catalog Number	Description
FMH2A03TR-EN23	3A MicroFlex AC Servo Drive. RS232. Encoder
FMH2A06TR-EN23	6A MicroFlex AC Servo Drive. RS232. Encoder
FMH2A09TR-EN23	9A MicroFlex AC Servo Drive. RS232. Encoder
FMH2A03TR-RN23	3A MicroFlex AC Servo Drive. RS232. Resolver
FMH2A06TR-RN23	6A MicroFlex AC Servo Drive. RS232. Resolver
FMH2A09TR-RN23	9A MicroFlex AC Servo Drive. RS232. Resolver
MFE230A003	3A MicroFlex e100 ETHERNET Powerlink AC Servo Drive
MFE230A006	6A MicroFlex e100 ETHERNET Powerlink AC Servo Drive
MFE230A009	9A MicroFlex e100 ETHERNET Powerlink AC Servo Drive

1) MicroFlex: For RS485 feedback option, substitute the last 2 for a 4. For example FMH2A03TR-EN23 becomes FMH2A03TR-EN43

2) Add /12 for the bulk pack option of 12 units

Fan Tray

Provides forced air cooling for MicroFlex and MicroFlex e100. Required if average current is above 3A RMS.



Catalog Number	Description
FAN001-024	Fan tray for single MicroFlex

EMC Filter Selection Guide

Recommended filters for Series-II drives



	230VAC 1 ϕ	115VAC 1 ϕ	230VAC 3 ϕ	230-460VAC 3 ϕ
2.5A	FI0029A00* FI0015A00	FI0015A00		FI0018A00
5A	FI0029A00* FI0015A02	FI0015A02		FI0018A00
7.5A	FI0029A00* FI0029A00*			FI0018A00
15A			FI0018A01	FI0018A01
20A				FI0018A01
27.5A				FI0018A01

Recommended filters for MicroFlex and MicroFlex e100

	230VAC 1 ϕ	230VAC 3 ϕ
3A	FI0029A00* FI0015A00	FI0018A00
6A	FI0029A00* FI0015A02	FI0018A00
9A	FI0029A00*	FI0018A03

* Footmount filter

H2 Servo Drive

Refer to catalog BR702 for full information on catalog numbers and accessories.



EuroFlex

Catalog Number	Description
EFL001-501	EuroFlex amplifier (5A/15A) - RS485 serial port
EFL001-502	EuroFlex amplifier (5A/15A) - RS232 serial port
BPL011-501	EuroFlex backplane
FI0015A02	EMC filter

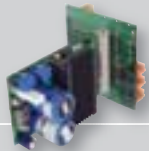

Braking/Regen Resistors

Catalog Number	Watts	Matched Drive
RG56	44W	3A MicroFlex
RG39	100W	6A / 9A MicroFlex 7.5A Series-II drive
RG22	100W	115VAC 7.5A Series-II drive
RG68	320W	3 phase 7.5A Series-II drive
RG27A	320W	3 phase 15A Series-II drive
RG23	640W	3 phase 20A Series-II drive
RG11	640W	3 phase 27.5A Series-II drive



Accessories

Programmable HMI Panels

Refer to catalog BR1202-H for full information.

Catalog Number	Description
KPD-KG420-20	4x20 character text/graphic display with numerical keypad.
KPD-KG420-30	4x20 character text/graphic display with numerical keypad and additional function keys.
KPD-KG840-10	8x40 character text/graphic display with alpha-numerical keypad
KPD-TS03M-10	3.8" mono touch screen
KPD-TS05M-10	5.6" mono touch screen
KPD-TS05C-10	5.6" color (STN) touch screen
KPD-TS10C-10	10.4" color (TFT) touch screen
KPD-TS12C-10	12.1" color (TFT) touch screen
KPD-OPTC	CANopen option card



CAN I/O Expansion and Operator Panels

For use with MintDrive-II with Option B fitted

Catalog Number	Description
ION001-501	CAN 8 Input Expansion Module (Baldor CAN only)
ION003-501	CAN 8 Output Expansion Module (Baldor CAN only)
ION002-501	CAN 8 Relay Expansion Module (Baldor CAN only)
ION004-501	CAN 24 I/O Expansion Module (Baldor CAN only)
KPD002-501	CAN Operator Panel (with display + keypad) (Baldor CAN only)
KPD002-505	Extended CAN Operator Panel (Baldor CAN only)



Encoder Splitter Boards

Catalog Number	Description
OPT029-501	4 channel encoder splitter board (DIN rail mount)
OPT029-502	8 channel encoder splitter board (DIN rail mount)

Power Supply Units

Catalog Number	Description
DR-75-24	24V Universal Power Supply. 75W/3.2A output
DR-120-24	24V Universal Power Supply. 120W/5.0A output
DRP-240-24	24V Universal Power Supply. 240W/10A output



Cables

Catalog Number	Description
CBL001-501	RS232 serial cable
CAN/Ethernet Cables Suitable for both Baldor CAN nodes and Ethernet e100 products	
CBL002CM-EXS	0.2 meter (0.8ft) Shielded RJ45 Cable
CBL005CM-EXS	0.5 meter (1.6ft) Shielded RJ45 Cable
CBL010CM-EXS	1 meter (3.2ft) Shielded RJ45 Cable
CBL020CM-EXS	2 meter (6.5ft) Shielded RJ45 Cable
CBL050CM-EXS	5 meter (16.3ft) Shielded RJ45 Cable
CBL100CM-EXS	10 meter (32.7ft) Shielded RJ45 Cable



Motor power, motor feedback and raw cables are also available. Please refer to brochure BR1202-H for further details.

Motor Solutions

For over 20 years, Baldor has been manufacturing and supplying high reliability servo motor solutions to worldwide applications. Baldor's servo motors are designed for industrial applications, superior durability and proven reliability. Our range of rotary motors are available as a high performance, low inertia family, or as a higher inertia family for more cost effective applications. Baldor's new stainless steel motors lead the way in solutions for harsh and washdown environments.

With the widest range of linear motors and stages on the market today, Baldor's linear motors lead the way and are ideally suited to applications requiring higher speeds or improved accuracy.

BSM Series Servo Motors

Refer to catalog BR1202-E for full information.

BSM motors are hard at work, increasing productivity, improving part quality, providing precision and reducing costs in many applications. These motors are available in two models, the BSM N-Series and the BSM C-Series.

Main Features

- › Popular shaft/mounting dimensions
- › High voltage insulation
- › High continuous rated operating temperature
- › Over temperature protection thermal switch
- › Stock and custom shafts and mountings
- › Standard windings for 160, 300 and 600 bus volts. Custom windings available
- › Choice of feedback options: resolver, encoder, EnDat, SSI

N-Series Servo Motors

- › Low inertia, high performance
- › Available in 5 frame sizes
- › Torque range from 0.45Nm (3.9 lb-in) to 40Nm (354 lb-in)

C-Series Servo Motors

- › High inertia, low cost solution
- › Available in 3 frame sizes
- › Torque range from 1.2Nm (10 lb-in) to 30Nm (265 lb-in)



Stainless Steel Configuration

Both motor families are available in a stainless steel configuration, offering the best protection for harsh environment. These motors are ideally suited for pharmaceutical and food applications.

Servo Gearheads

A range of high precision planetary gearheads are available for the BSM servo motor range. These are designed for applications requiring precision, durability and long, trouble free, operation.



Linear Motors and Stages

Refer to catalog BR1202-G for full information.

Used in thousands of applications worldwide, Baldor provides industry with the widest range of linear motors and linear stages. Linear motors provide unique speed and positioning performance advantages. The direct-coupled motion eliminates mechanical transmission devices and offer substantial improvements over applications using ball screws, timing belts, etc. The rugged mechanical design provides accurate motion and precision positioning for millions of cycles. Products include:

- › Cog free linear motors for high precision, high speed applications
- › Single and dual axis stepper motors
- › Cog free linear motor stages, including XYZ stages
- › HyCore™ linear motor for low cost linear motor applications
- › Linear induction motors





DSM - Integrated Stepper Motor and Drive

Refer to flyer **FL1851** for full information.

Baldor's new DSM integrated stepper motor and microstepping drive provides a cost effective solution for stepper motor applications. The unique design integrates a high performance micro-stepping drive onto a stepper motor, providing a compact and reliable solution. Wiring is reduced to just pulse and direction plus power. The range is available in NEMA frames sizes 17, 23 and 34 with torque outputs from 22 to 748 N-cm (32 to 1061 oz-in)

DC Servo Motors

Refer to catalog **BR1202-F** for full information.

The Baldor family of DC servo motors (PMDC) provide continuous torques from 0.21Nm to 6.55Nm (1.8 lb.-in to 58 lb.-in.) These high performance motors are designed to meet the demanding requirements of industrial motion control. A wide variety of windings and feedback devices are available for your application needs.



Motion Control Solutions

With today's automation applications demanding increasing speed and flexibility to stay ahead, finding a control solution to meet those demands can be difficult. Baldor has the answer. Utilizing a high performance, state of the art processor core and coupled with the power, flexibility and ease of use of Baldor's Mint programming language, the NextMove range of motion controllers can take on the most demanding of multi-axis applications.

A Flexible Solution

Baldor's motion controllers have been at the heart of automation machines for nearly two decades. The NextMove motion controller family is synonymous with power, flexibility and versatility. Operating around the world, NextMove has met the demands of a rapidly developing automation world, providing increased productivity, reliability and flexibility.

NextMove controllers are available in a number of configurations including stand-alone with RS232/485, USB and Ethernet interfaces and PCI-bus. Controllers are available for controlling 1 through to 16 axes of closely coordinated motion, all programmed using Baldor's acclaimed Mint programming language



Baldor's Motion Solutions Catalogs

- BR1202-A** Motion Control Solutions
- BR1202-B** Mint® Software and Applications
- BR1202-C** NextMove Multi-Axis Motion Controllers
- BR1202-D** AC Servo Drives
- BR1202-E** AC Servo Motors
- BR1202-F** DC Servo Motors and Drives
- BR1202-G** Linear Motors and Stages
- BR1202-H** Motion Product Accessories
- BR1202-I** Real-Time Ethernet Motion Solutions

World Headquarters (U.S.A.)

Baldor Electric Company

Tel: +1 479 646-4711
Fax: +1 479 648-5792
E-mail: sales.us@baldor.com

Australia

Tel: +61 2 9674 5455
Fax: +61 2 9674 2495
E-mail: sales.au@baldor.com

China

Tel: +86-21-64473060
Fax: +86-21-64078620
E-mail: sales.cn@baldor.com

Germany

Tel: +49 89 905 08-0
Fax: +49 89 905 08-490
E-mail: sales.de@baldor.com

India

Tel: +91 20 25 45 95 31/32
Fax: +91 20 25 45 95 30
E-mail: sales.in@baldor.com

Italy

Tel: +41 91 640 9950
Fax: +41 91 630 2633
E-mail: sales.it@baldor.com

Japan

Tel: +81 45-412-4506
Fax: +81 45-412-4507
E-mail: sales.jp@baldor.com

Korea

Tel: +(82-32) 508 3252
Fax: +(82-32) 508 3253
E-mail: sales.kr@baldor.com

Mexico

Tel: +52 477 761 2030
Fax: +52 477 761 2010
E-mail: sales.mx@baldor.com

Singapore

Tel: +65 744 2572
Fax: +65 747 1708
E-mail: sales.sg@baldor.com

Switzerland

Tel: +41 52 647 4700
Fax: +41 52 659 2394
E-mail: sales.ch@baldor.com

United Kingdom

Tel: +44 1454 850000
Fax: +44 1454 859001
E-mail: sales.uk@baldor.com

For additional office locations visit

www.baldor.com

Local Distributor: